

Pioneer

Service Manual

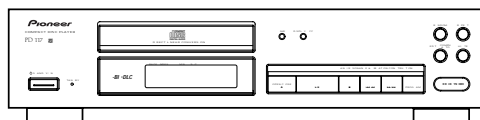

ORDER NO.
RRV2118

COMPACT DISC PLAYER **PD-117**

THIS MANUAL IS APPLICABLE TO THE FOLLOWING MODEL(S) AND TYPE(S).

Type	Model	Power Requirement	The voltage can be converted by the following method.
	PD-117		
WPWXJ	○	AC220-240V	—————
RDXJ	○	AC110-127V/ 220-240V	With the voltage selector
RLXJ	○	AC110-120V/ 220-240V	With the voltage selector

CONTENTS

1. SAFETY INFORMATION	2	7. GENERAL INFORMATION	25
2. EXPLODED VIEWS AND PARTS LIST	3	7.1 DISPLAY	25
3. SCHEMATIC DIAGRAM	8	7.2 BLOCK DIAGRAM	26
4. PCB CONNECTION DIAGRAM	11	8. PANEL FACILITIES AND SPECIFICATIONS	27
5. PCB PARTS LIST	15		
6. ADJUSTMENT	17		

1. SAFETY INFORMATION

This service manual is intended for qualified service technicians; it is not meant for the casual do-it-yourselfer. Qualified technicians have the necessary test equipment and tools, and have been trained to properly and safely repair complex products such as those covered by this manual. Improperly performed repairs can adversely affect the safety and reliability of the product and may void the warranty. If you are not qualified to perform the repair of this product properly and safely, you should not risk trying to do so and refer the repair to a qualified service technician.

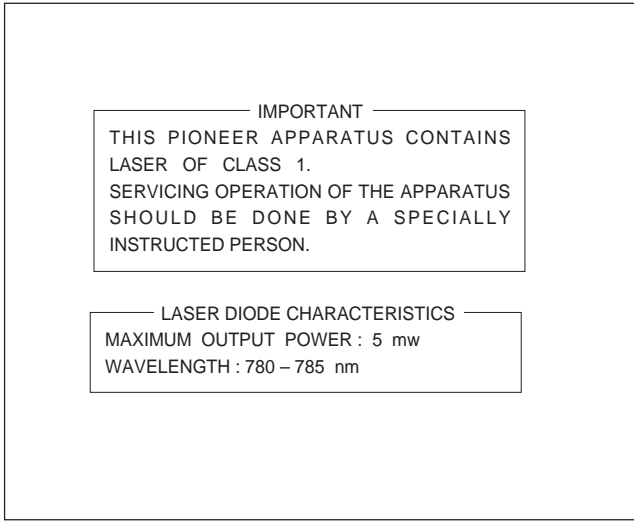

LABEL CHECK

WPWXJ and RLXJ types

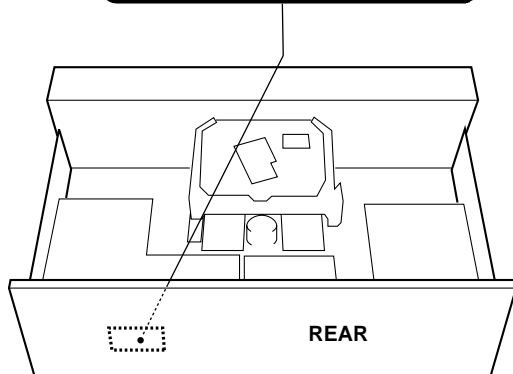
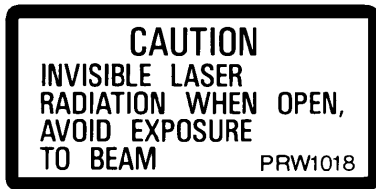

Additional Laser Caution

1. Laser Interlock Mechanism
 The position of the switch (S601) for detecting loading state is detected by the system microprocessor, and the design prevents laser diode oscillation when the switch (S601) is not on CLMP terminal side (CLMP signal is OFF or high level.). Thus, the interlock will no longer function if the switch (S601) is deliberately set to CLMP terminal side (low level).
 The interlock also does not function in the test mode*.
 Laser diode oscillation will continue, if pin 33 of CXA1782CQ (IC151) on the MAIN BOARD ASSY is connected to GND, or pin 22 of IC301(LDON) is connected to low level (ON), or else the terminals of Q151 are shorted to each other (fault condition).

2. When the cover is opened with the servo mechanism block removed and turned over, close viewing of the objective lens with the naked eye will cause exposure to a Class 1 laser beam.

* Refer to page 18.

2. EXPLODED VIEWS AND PARTS LIST

- NOTES :
- Parts marked by “NSP” are generally unavailable because they are not in our Master Spare Parts List.
 - The \triangle mark found on some component parts indicates the importance of the safety factor of the part. Therefore, when replacing, be sure to use parts of identical designation.
 - Screw adjacent to \blacktriangledown mark on the product are used for disassembly.

2.1 PACKING

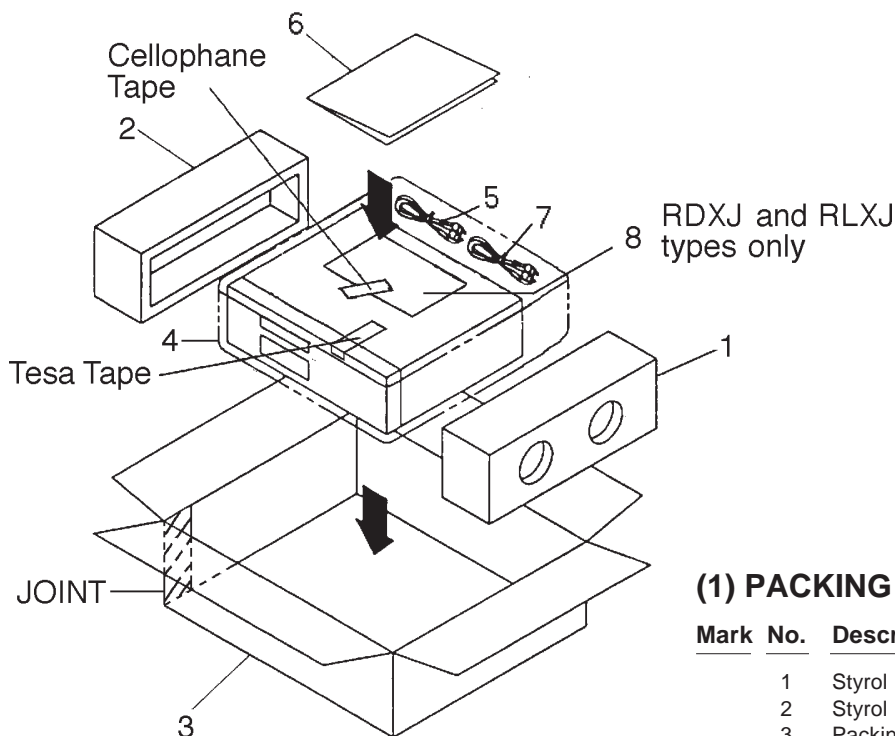

(1) PACKING PARTS LIST

Mark	No.	Description	Part No.
	1	Styrol Protector R	PHA1289
	2	Styrol Protector L	PHA1290
	3	Packing Case	PHG2369
	4	Packing Sheet (750 × 600 × 0.5)	Z23-007
	5	Output Cable (L=1.0m)	PDE1248
	6	Operating Instructions	See Contrast table (2)
	7	Control Cable (L=1.0m)	PDE1247
	8	Caution 220V Label	See Contrast table (2)

(2) CONTRAST TABLE

PD-117/WPWXJ, RDXJ and RLXJ are constructed the same except for the following:

Mark	No.	Symbol and Description	Part No.			Remarks
			WPWXJ type	RDXJ type	RLXJ type	
	6	Operating Instructions (English/Spanish/Chinese)	Not used	PRE1280	PRE1280	
	6	Operating Instructions (English)	PRB1287	Not used	Not used	
	8	CAUTION 220V LABEL	Not used	ARR1003	ARR1003	

2.2 EXTERIOR (1/2)

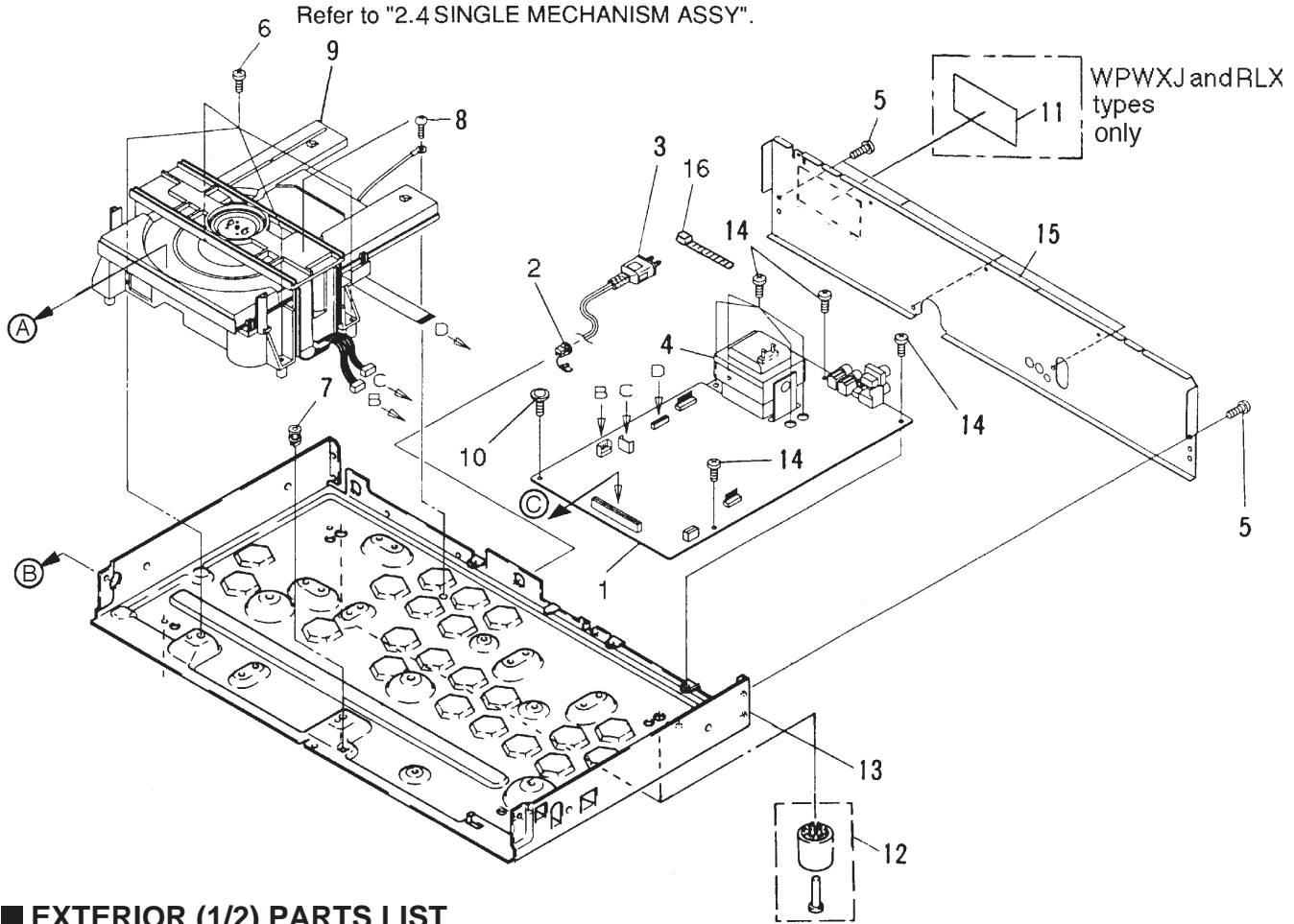

EXTERIOR (1/2) PARTS LIST

(1) EXTERIOR PARTS LIST

Mark	No.	Description	Part No.	Mark	No.	Description	Part No.
	1	MOTHER BOARD ASSY	See Contrast table (2)		11	Caution Label	PRW1018
△	2	Strain Relief	CM-22B		12	Foot Assy	AEC1531
△	3	AC Power Cord	See Contrast table (2)	NSP	13	Under Base	PNA2177
△	4	Power Transformer	See Contrast table (2)		14	Screw	BBZ30P060FMC
	5	Screw	FBZ30 P080FZK		15	Rear Base	See Contrast table (2)
	6	Screw	BBZ30P160FMC		16	Binder (SKB-90BK)	ZCA-SKB90BK
NSP	7	PCB Spacer	PNY-404				
	8	Screw	PDZ30P050FMC				
NSP	9	Single Mechanism Assy	PXA1593				
	10	Screw	IPZ30P150FCC				

(2) CONTRAST TABLE

PD-117/WPWXJ, RDXJ and RLXJ are constructed the same except for the following:

Mark	No.	Symbol and Description	Part No.			Remarks
			WPWXJ type	RDXJ type	RLXJ type	
△	1	MOTHER BOARD ASSY	PWM2137	PWM2136	PWM2136	
△	3	AC Power Cord	ADG1123	PDG1013	PDG1003	
△	4	Power Transformer	PTT1236	PTT1238	PTT1238	
	15	Rear Base	PNA2494	PNA2492	PNA2493	
	17	Caution Label	PRW1018	Not used	PRW1018	

2.3 EXTERIOR (2/2)

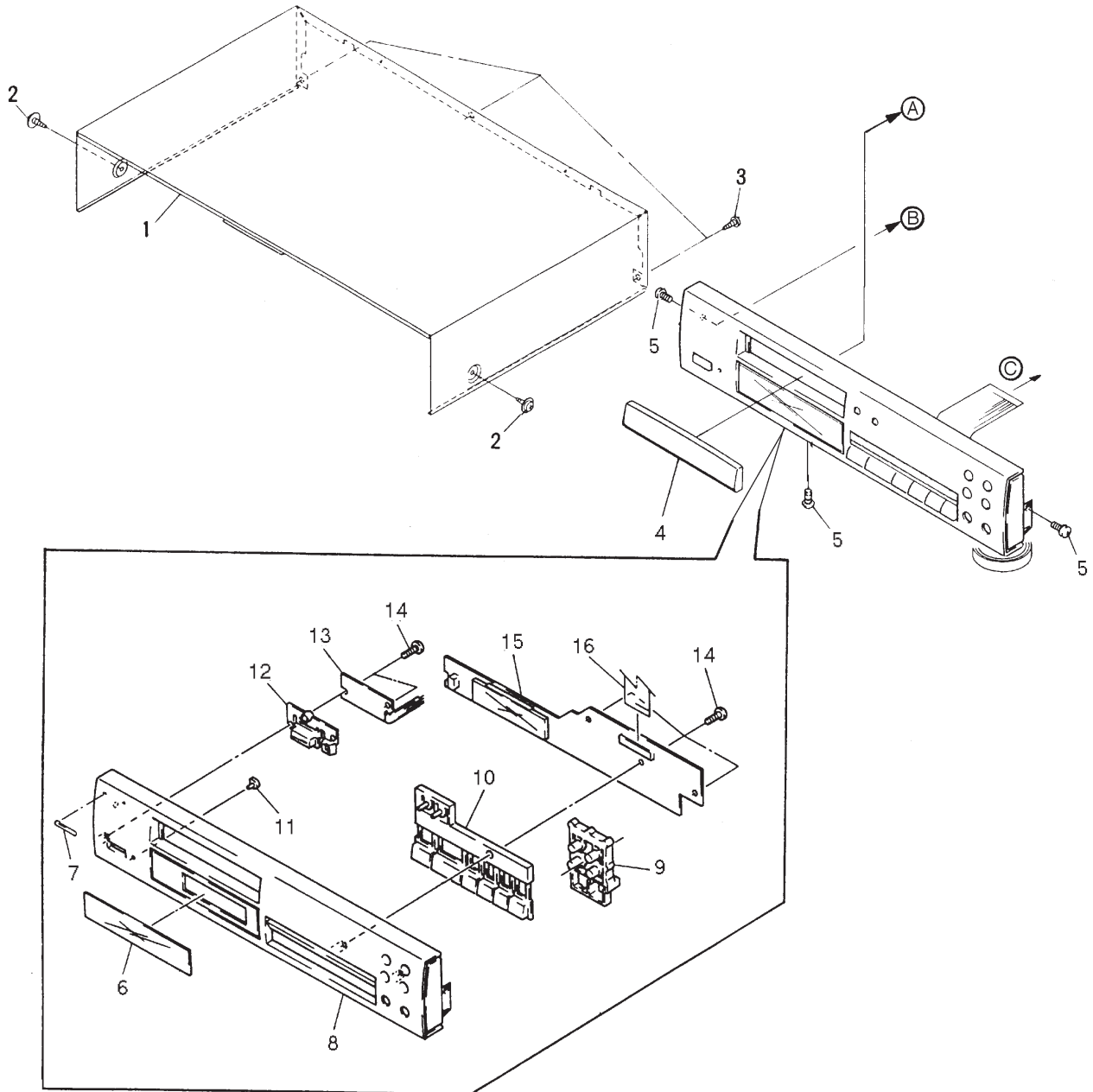

■ EXTERIOR (2/2) PARTS LIST

Mark No.	Description	Part No.	Mark No.	Description	Part No.	
1	Bonnet	PYY1182	11	LED Lens	PNW2019	
2	Screw	FBT40P080FZK	12	Power Button	PAC1708	
3	Screw	BBZ30P080FZK	NSP	13	SW BOARD ASSY	PWZ2942
4	Tray Name Plate	PNW2923	14	Screw	PPZ30P100FMC	
5	Screw	IBZ30P080FCC	NSP	15	DISPLAY BOARD ASSY	PWZ2935
6	Display Window	PAM1799	16	30P F · F · C/30V	PDD1049	
7	Name Plate	PAM1776				
8	Function Panel	PNW2910				
9	Mode Button	PAC1796				
10	Operate Button	PAC1798				

2.4 SINGLE MECHANISM ASSY

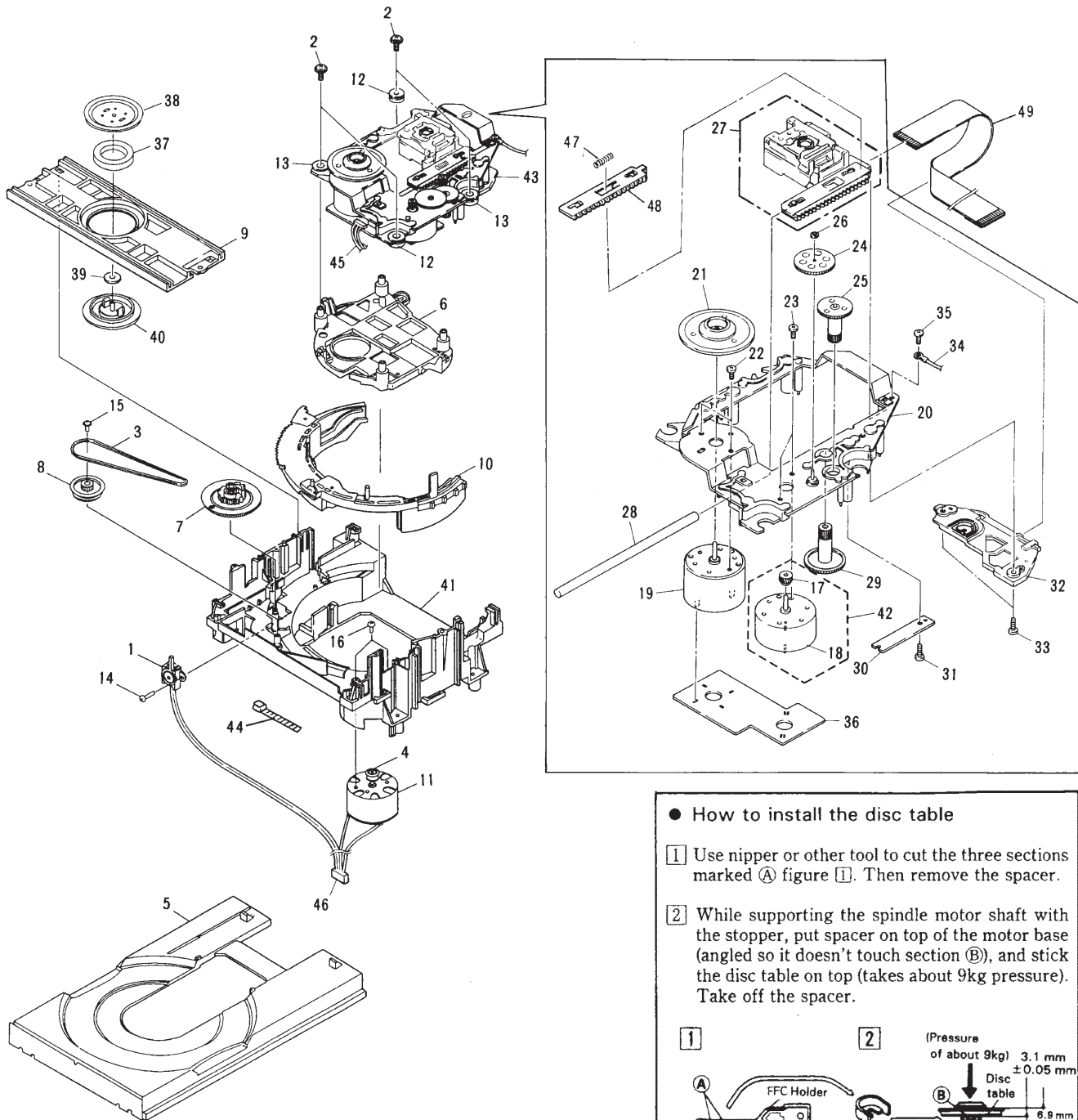

● How to install the disc table

- 1 Use nipper or other tool to cut the three sections marked (A) figure 1. Then remove the spacer.
- 2 While supporting the spindle motor shaft with the stopper, put spacer on top of the motor base (angled so it doesn't touch section (B)), and stick the disc table on top (takes about 9kg pressure). Take off the spacer.

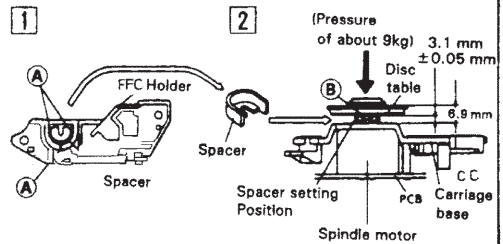

■ SINGLE MECHANISM ASSY PARTS LIST

Mark	No.	Description	Parts No.	Mark	No.	Description	Parts No.
	1	Lever Switch (S601)	DSK1003		26	Washer	WT12D032D025
	2	Float Screw	PBA1048		27	PICK UP ASSY-S	PEA1335
	3	Rubber Belt	PEB1193		28	Guide Bar	PLA1094
	4	Motor Pulley	PNW1634		29	Gear 1	PNW2052
	5	Tray Black V	PNW2455		30	Gear Stopper	PNB1303
	6	Float Base	PNW2032		31	Screw	BBZ20P060FMC
	7	Drive Gear 2	PNW2369		32	FFC Holder	PNW2734
	8	Gear Pulley	PNW2034		33	Screw	BPZ26P100FMC
	9	Clamper Base	PNW2375		34	Earth Lead Unit	PDF1104
	10	Clamp Cam	PNW2364		35	Screw	BBZ26P060FMC
	11	D.C. Motor (0.75W, LOADING)	PXM1010	NSP	36	MECHANISM BOARD ASSY	PWX1192
	12	Float Rubber B	REB1287		37	Clamp Magnet	PMF1014
	13	Float Rubber G	REB1288		38	Yoke	PNB1216
	14	Screw	BPZ26P080FMC	NSP	39	H Rubber	PEB1249
	15	Screw	Z39-019		40	Clamper S	PNW1609
	16	Screw	BMZ26P040FMC		41	Loading Base	PNW2376
	17	Pinion Gear	PNW2055		42	D.C. Motor Assy (CARRIAGE)	PEA1246
NSP	18	D.C. Motor (CARRIAGE)	PXM1027	NSP	43	SERVO MECHANISM ASSY	PXA1596
	19	D.C. Motor ASSY (SPINDLE)	PEA1235		44	Binder	Z09-056
	20	Carriage Base	PNW2699		45	Connector Assy (4P)	RDE1043
	21	Disc Holder	PNW1608		46	Connector Assy (5P)	PDE1239
	22	Screw	JFZ20P030FNI		47	PU Rack Spring	ABH7077
	23	Screw	JFZ17P025FZK		48	Rack Holder	PNW2056
	24	Gear 3	PNW2054		49	16P F·F·C/30V	PDD1185
	25	Gear 2	PNW2053				

3. SCHEMATIC DIAGRAM

3.1 MOTHER BOARD ASSY, DISPLAY BOARD ASSY and SW BOARD ASSY

A

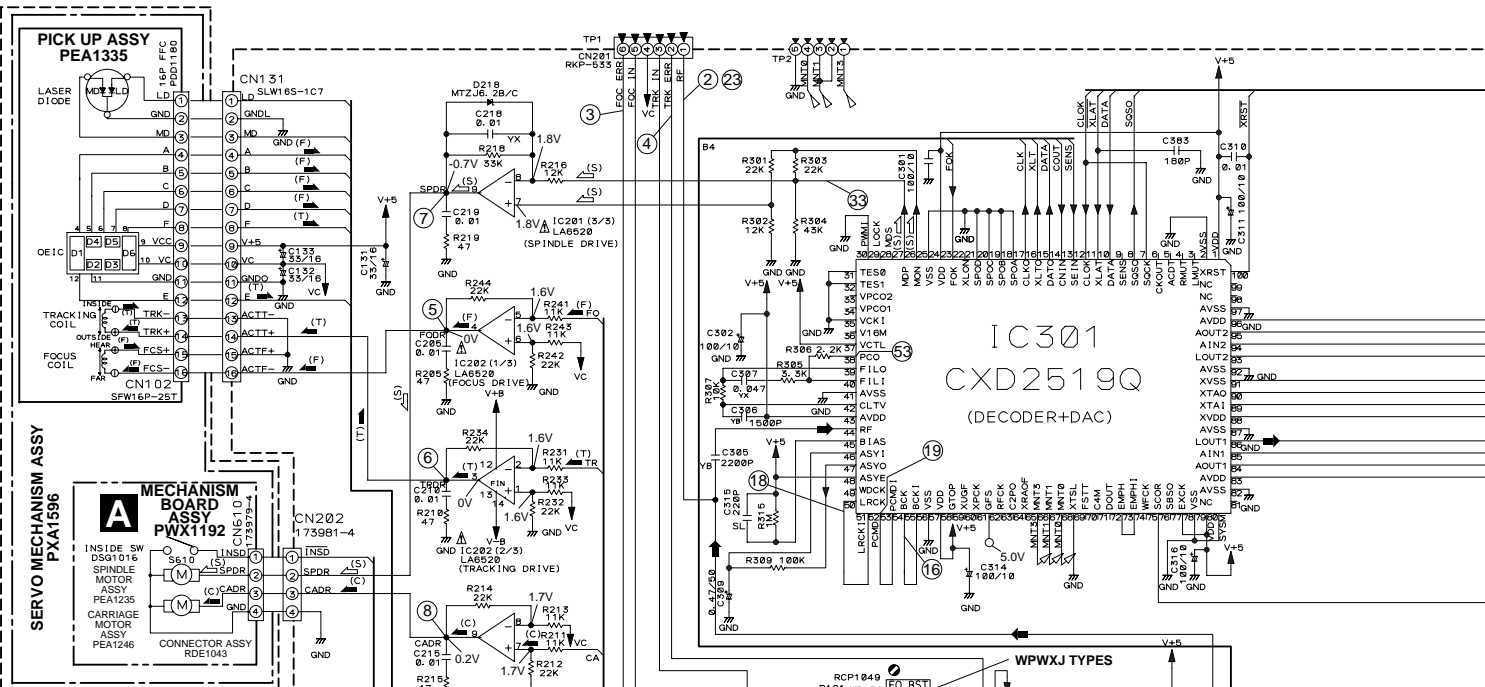

B

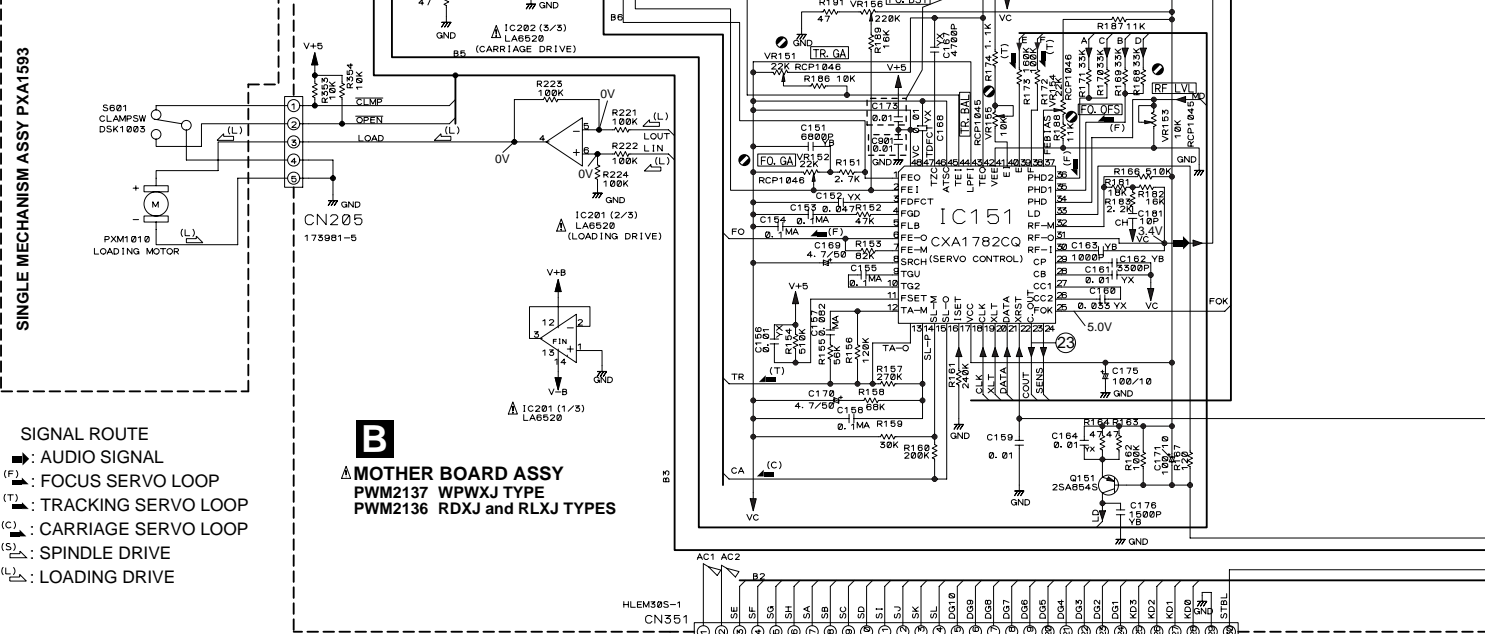

C

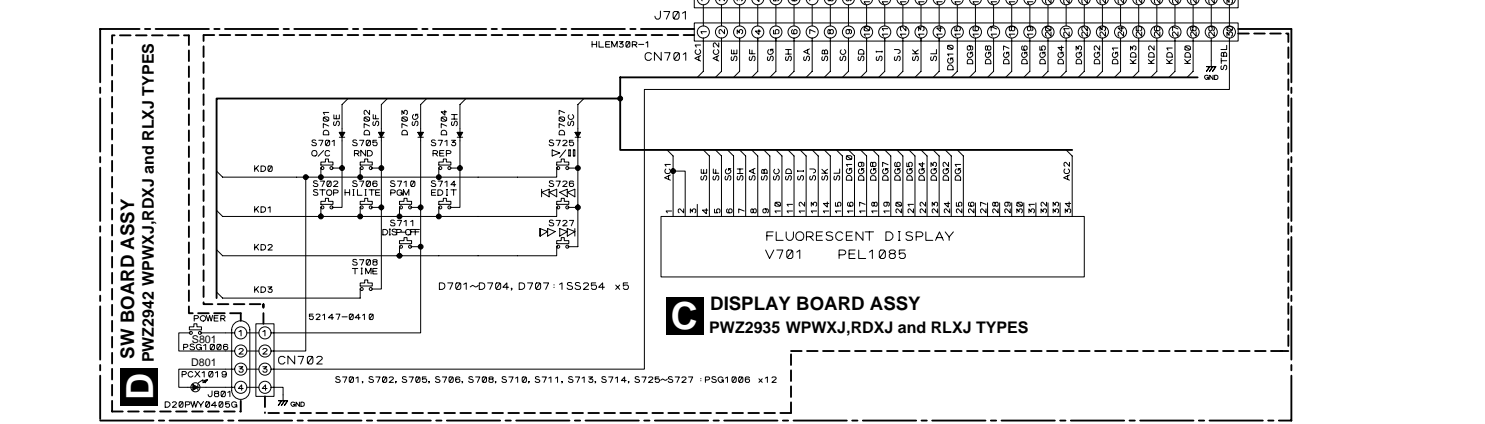

D



Note: When ordering service parts, be sure to refer to "EXPLODED VIEWS AND PARTS LIST" or "PCB PARTS LIST".

IC351(PD4835A)

PIN No.	1	2	3	4	5	6	7	8	9	10	11	12	13	14	15	16	17	18	19	20				
Volta- ge(V)	PLAY	5.0	-23.2	-23.2	-23.2	-23.2	-23.2	-23.2	-23.2	-23.2	-23.2	-23.2	-23.2	-23.2	-23.2	-23.2	-23.2	-23.2	-23.2	-23.2				
	STOP	5.0	-23.8	-23.7	-23.7	-23.8	-23.8	-23.8	-23.8	-23.8	-23.8	-23.8	-23.8	-23.8	-23.8	-23.8	-23.8	-23.8	-23.8	-23.8				
PIN No.	21	22	23	24	25	26	27	28	29	30	31	32	33	34	35	36	37	38	39	40				
Volta- ge(V)	PLAY	—	—	—	—	4.9	—	—	—	—	4.9	4.8	4.0	—	4.9	4.0	0.1	0.1	1.0	1.0				
	STOP	—	—	—	—	4.9	-25.8	26.2	—	—	4.8	4.9	2.5	2.9	4.9	2.3	0.0	0.0	1.3	1.3				
PIN No.	41	42	43	44	45	46	47	48	49	50	51	52	53	54	55	56	57	58	59	60	61	62	63	64
Volta- ge(V)	PLAY	1.0	1.0	5.0	1.0	—	1.0	1.0	1.0	5.0	4.9	4.9	4.9	4.9	4.9	2.3	2.2	0.1	0.1	4.9	0.1	0.1	0.1	0.1
	STOP	1.3	1.3	5.0	1.2	-0.9	1.2	1.2	1.2	-1.0	6.8	1.2	4.9	4.9	4.9	2.3	2.2	0.1	0.1	4.9	0.1	0.1	0.1	0.1

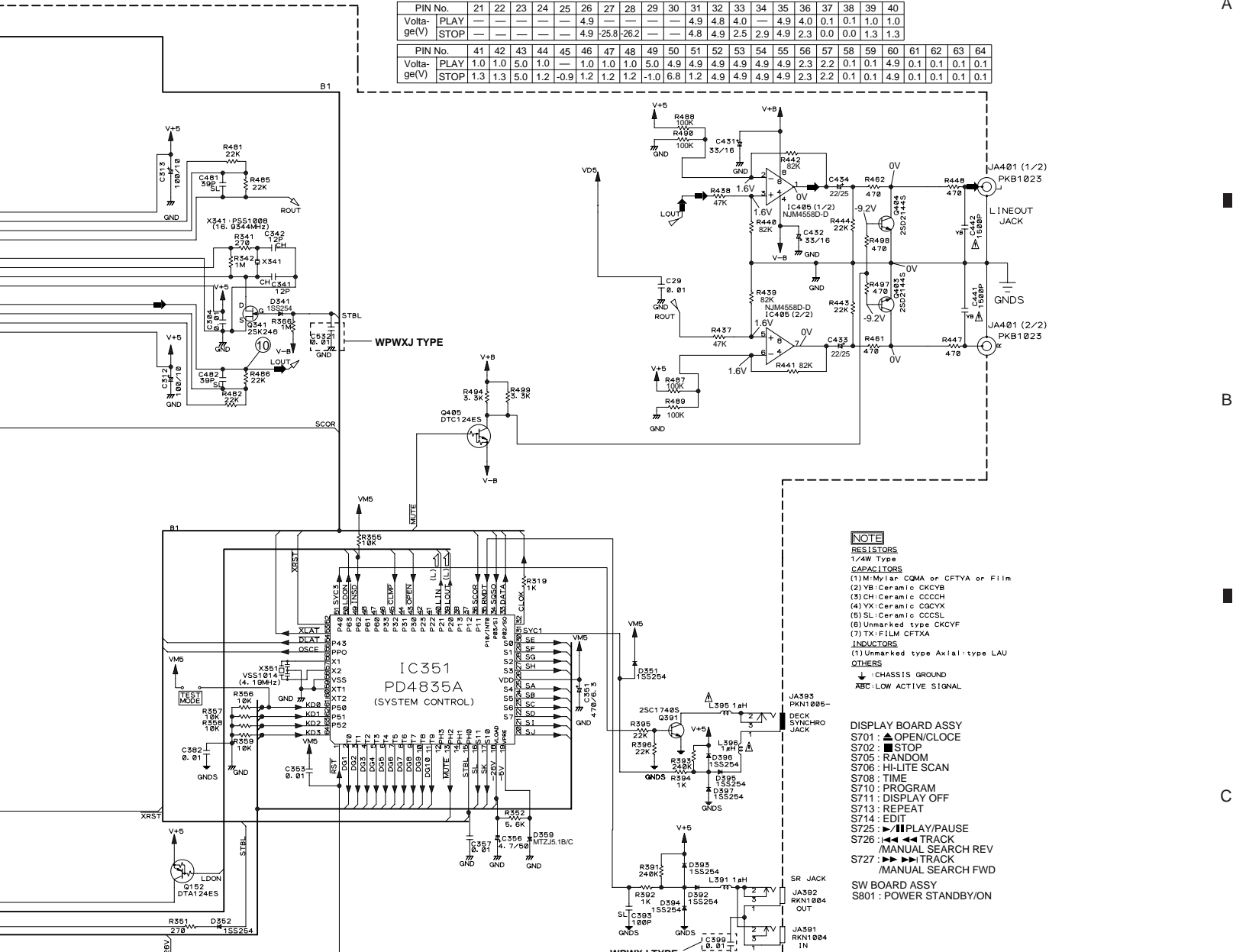

- NOTE**
- RESISTORS: 1/4W Type
 - CAPACITORS: (1)M: Mylar CQMA or CFTYA or Film; (2)V: Ceramic CKCYB; (3)CH: Ceramic CCCCX; (4)X: Ceramic CCCCX; (5)SL: Ceramic CCCCX; (6)Unmarked type CKCYF; (7)X: FILM CFTXA
 - INDUCTORS: (1)Unmarked type Axial-type LAU
 - OTHERS: ↓ CHASSIS GROUND; ABC: LOW ACTIVE SIGNAL

- DISPLAY BOARD ASSY**
- S701: OPEN/CLOSE
 - S702: STOP
 - S705: RANDOM
 - S706: HI-LITE SCAN
 - S708: TIME
 - S710: PROGRAM
 - S711: DISPLAY OFF
 - S713: REPEAT
 - S714: EDIT
 - S725: ◀▶ TRACK
 - S726: ◀▶ TRACK
 - S727: ◀▶ TRACK
- SW BOARD ASSY**
- S801: POWER STANDBY/ON

CAUTION: FOR CONTINUED PROTECTION AGAINST RISK OF FIRE, REPLACE WITH SAME TYPE NO. ICP-N10, MFD BY ROHM CO., LTD. FOR IC31 AND IC34.

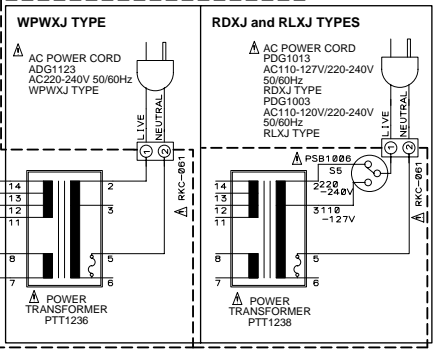









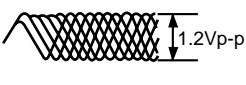

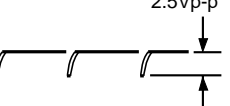

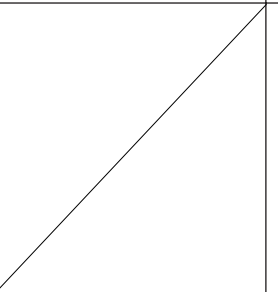
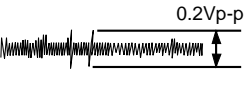
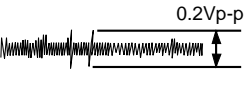

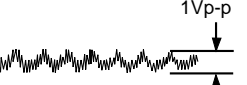

B MOTHER BOARD ASSY Waveforms

*1 50T-JUMP: After switching to the pause mode, press the manual search key.

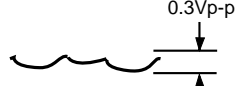
*2 FOCUS-IN: Press the play key without loading a disc.

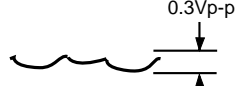
Note: The encircled numbers denote measuring point in the schematic diagram.

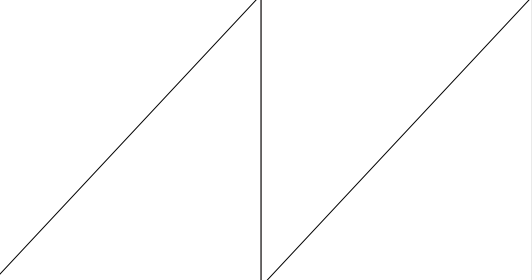
<p>2 TP1- Pin 1 : PLAY MODE (RF) H : 500nsec/div</p> 	<p>5 IC202- Pin 4 : PLAY MODE (FODR) H : 1msec/div</p> 	<p>8 IC202- Pin 9 : TRACK SEARCH MODE (CADR) H : 200msec/div</p> 	<p>33 IC301- Pin 27 : PLAY MODE (MDP) H : 2μsec/div</p> 
<p>2 TP1- Pin 1 : TRACK SEARCH MODE (RF) H : 200 μsec/div</p> 	<p>6 IC202- Pin 3 : PLAY MODE (TRDR) H : 1msec/div</p> 		<p>53 IC301- Pin 38 : PLAY MODE (PCO) H : 10μsec/div</p> 
<p>3 TP1- Pin 6 : PLAY MODE (FOER) H : 10msec/div</p> 	<p>6 IC202- Pin 3 : 50T-JUMP(*1) MODE (TRDR) H : 1msec/div</p> 		<p>16 IC301- Pin 54 : PLAY MODE (1kHz) (BCLK) H : 500nsec/div</p> 
<p>4 TP1- Pin 2 : PLAY MODE (TRER) H : 10msec/div</p> 	<p>7 IC201- Pin 9 : PLAY MODE (SPDR) H : 50msec/div</p> 	<p>18 IC301- Pin 50 : PLAY MODE (1kHz) (LRCK) H : 10μsec/div</p> 	
<p>4 TP1- Pin 2 : 50T- JUMP(*1)MODE (TRER) H : 1msec/div</p> 	<p>7 IC201- Pin 9 : TRACK SEARCH MODE (SPDR) H : 50msec/div</p> 	<p>19 IC301- Pin 52 : PLAY MODE (1kHz) (DATA) H : 500nsec/div</p> 	
<p>5 IC202- Pin 4 : FOCUS-IN(*2) MODE (FODR) H : 200msec/div</p> 	<p>8 IC202- Pin 9 : PLAY MODE (CADR) H : 2sec/div</p> 	<p>23 TRACK SEARCH MODE Upper:TP1-Pin1(RF) Lower:IC151-Pin 23 (C.OUT) H : 200μsec/div</p> 	

4. PCB CONNECTION DIAGRAM

NOTE FOR PCB DIAGRAMS :

1. Part numbers in PCB diagrams match those in the schematic diagrams.
2. A comparison between the main parts of PCB and schematic diagrams is shown below.

SIDE A

Symbol In PCB Diagrams	Symbol In Schematic Diagrams	Part Name
		Transistor
		Transistor with resistor
		Field effect transistor
		Resistor array
		3-terminal regulator

3. The parts mounted on this PCB include all necessary parts for several destinations.
For further information for respective destinations, be sure to check with the schematic diagram.
4. View point of PCB diagrams.

A MECHANISM BOARD ASSY

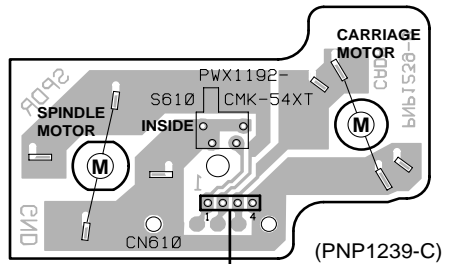

B CN202

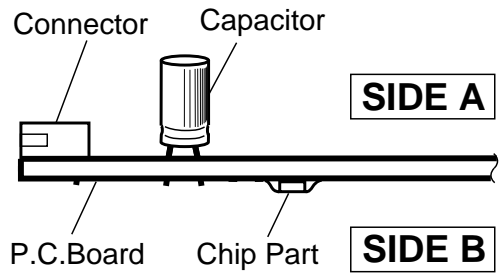

D SW BOARD ASSY

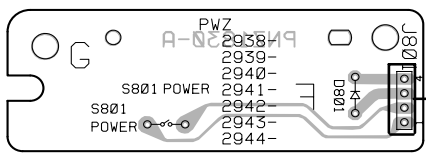

C CN702

(PNP1386-A)

B MOTHER BOARD ASSY

A

AC POWER CORD

PRIMARY

NEUTRAL LIVE

VOLTAGE SELECTOR

B

To PICKUP ASSY
CN102

C

CN610

To LOADING MOTOR
and CLAMP SW

D

C CN701

PNP1424-B

Q391
Q452
Q454
Q404
Q403
Q453
Q451

Q405
IC406

IC405

IC31

VR151
VR152

IC401

IC34

IC202

IC21

Q321

VR155

VR156

Q341

VR153

VR154

Q151

Q152

Q201

B MOTHER BOARD ASSY

SIDE B

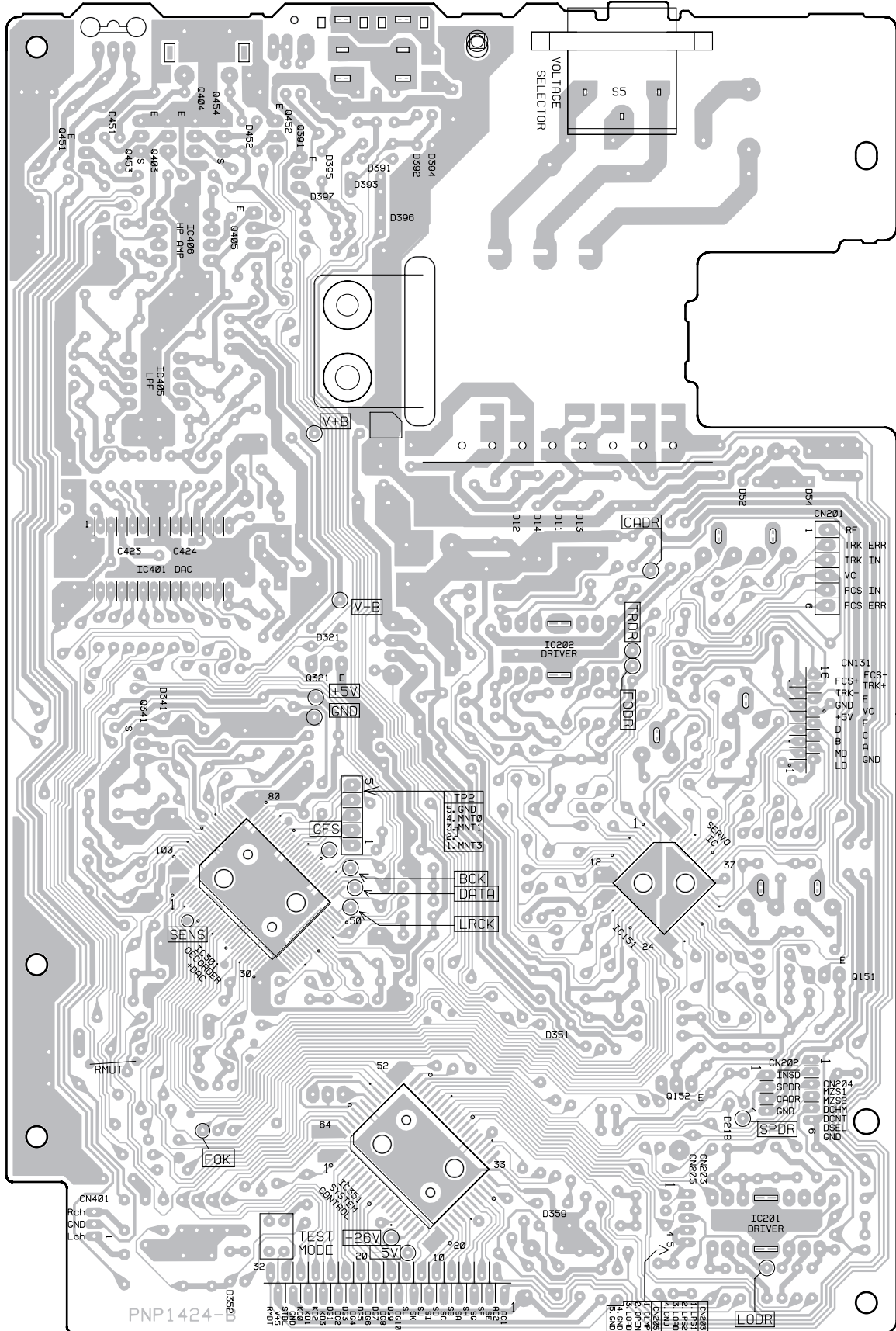

IC301
IC151

IC351

PNP1424

PNP1424-B

A

C DISPLAY BOARD ASSY

SIDE A

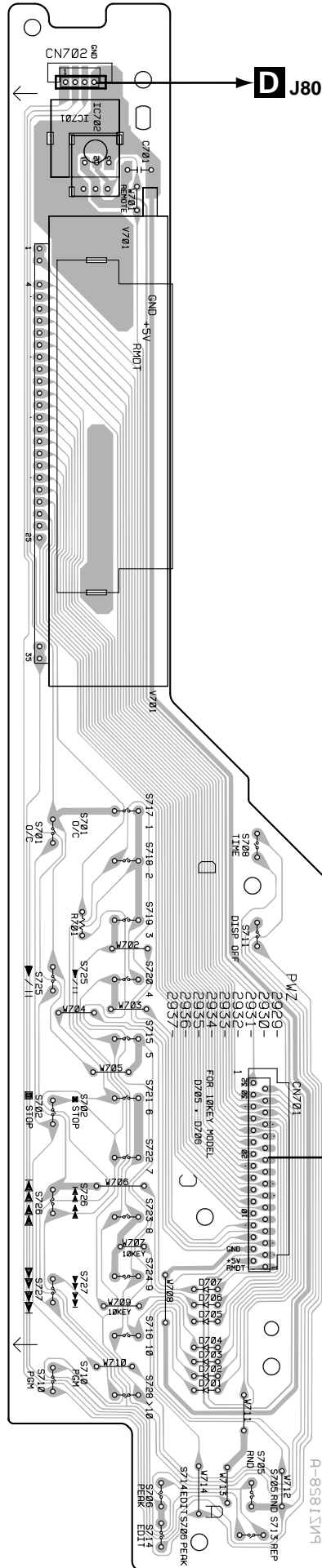

(PNP1386-A)

C

5. PCB PARTS LIST

- NOTES :
- Parts marked by “ NSP ” are generally unavailable because they are not in our Master Spare Parts List.
 - The \triangle mark found on some component parts indicates the importance of the safety factor of the part. Therefore, when replacing, be sure to use parts of identical designation.
 - When ordering resistors, first convert resistance values into code form as shown in the following examples.
- Ex. 1 When there are 2 effective digits (any digit apart from 0), such as 560 ohm and 47k ohm (tolerance is shown by $J = 5\%$, and $K = 10\%$).
- 560 $\Omega \rightarrow 56 \times 10^1 \rightarrow 561$ RD1/4PU $\begin{matrix} 5 & 6 & 1 \\ \hline & & J \end{matrix}$
 47k $\Omega \rightarrow 47 \times 10^3 \rightarrow 473$ RD1/4PU $\begin{matrix} 4 & 7 & 3 \\ \hline & & J \end{matrix}$
 0.5 $\Omega \rightarrow R50$ RN2H $\begin{matrix} R & 5 & 0 \\ \hline & & K \end{matrix}$
 1 $\Omega \rightarrow 1R0$ RS1P $\begin{matrix} 1 & R & 0 \\ \hline & & K \end{matrix}$
- Ex. 2 When there are 3 effective digits (such as in high precision metal film resistors).
- 5.62k $\Omega \rightarrow 562 \times 10^1 \rightarrow 5621$ RN1/4PC $\begin{matrix} 5 & 6 & 2 & 1 \\ \hline & & & F \end{matrix}$

■ LIST OF WHOLE PCB ASSEMBLIES

Mark	Symbol and Description	Part No.			Remarks
		WPWXJ	RDXJ	RLXJ	
\triangle	MOTHER BOARD ASSY	PWM2137	PWM2136	PWM2136	
\triangle NSP	SUB BOARD ASSY	PWX1398	PWX1398	PWX1398	
	└ DISPLAY BOADR ASSY	PWZ2935	PWZ2935	PWZ2935	
	└ SW BOARD ASSY	PWZ2942	PWZ2942	PWZ2942	
NSP	SINGLE MECHANISM ASSY	PXA1593	PXA1593	PXA1593	
	└ SERVO MECHANISM ASSY	PXA1596	PXA1596	PXA1596	
	└ MECHANISM BOARD ASSY	PWX1192	PWX1192	PWX1192	

■ CONTRAST OF PCB ASSEMBLIES

MOTHER BOARD ASSY

PWM2136 and PWM2137 are constructed the same except for the following:

Mark	Symbol and Description	Part No.		Remarks
		PWM2137	PWM2136	
\triangle	C173, C399, C5321 S5 Voltage Selector	CKCYF103Z50 Not used	Not used PSB1006	

■ PARTS LIST FOR PD-117/WPWXJ

Mark	No.	Description	Part No.	Mark	No.	Description	Part No.
		B MOTHER BOARD ASSY					
		SEMICONDUCTORS					
		IC151	CXA1782CQ			Q391	2SC1740S
		IC301	CXD2519Q			Q403, Q404	2SD2144S
\triangle		IC31, IC34	ICP-N10			Q341	2SK246
\triangle		IC201, IC202	LA6520			Q152	DTA124ES
		IC405	NJM4558D-D			Q405	DTC124ES
		IC351	PD4835A			D341, D351, D352, D392- D397	1SS254
\triangle		IC21	PQ05RR12			D54	MTZJ18B/C
		Q151	2SA854S	\triangle		D359	MTZJ5.1B/C
						D218	MTZJ6.2B/C
						D11- D14, D52	S5688G

Mark No. Description Part No.

COILS AND FILTERS

	L351 (RADIAL INDUCTOR)	LFA100J
	L391 (RADIAL INDUCTOR)	LFA1R0J
△	L395, L396 (RADIAL INDUCTOR)	LFA1R0J

CAPACITORS

	C181	CCCCH100D50
	C341, C342	CCCCH120J50
	C393	CCCCL101J50
	C383	CCCCL181J50
	C315	CCCCL221J50
	C481, C482	CCCCL390J50
	C309	CEASR47M50
	C171, C175, C301, C311- C314	CEAS101M10
	C316, C302	CEAS101M10
	C52	CEAS101M35
	C26	CEAS102M16
	C433, C434	CEAS220M25
	C27, C131- C133, C431, C432	CEAS330M16
	C25	CEAS332M16
	C169, C170, C356	CEAS4R7M50
	C351	CEAS471M6R3
	C156, C161, C164, C168, C218	CGCYX103K25
	C160	CGCYX333K25
	C167	CGCYX472K25
	C152, C307	CGCYX473K25
	C157	CGCYX823K25
	C163	CKCYB102K50
	C176, C306, C441, C442	CKCYB152K50
	C305	CKCYB222K50
	C162	CKCYB332K50
	C151	CKCYB682K50
	C29, C159, C173, C205, C210	CKCYF103Z50
	C215, C219, C304, C310, C353	CKCYF103Z50
	C357, C382, C399, C5321	CKCYF103Z50
△	C11, C13, C15, C16, C17	CKCYF103Z50
	C153, C154, C155, C158	CQMBA104J50

RESISTORS

	VR153, VR155 (10kΩ- B)	RCP1045
	VR151, VR152, VR154 (22kΩ- B)	RCP1046
	VR156 (220kΩ- B)	RCP1049
	Other Resistors	RD1/4PU□□□J

OTHERS

	CN202 MT 4P CONNECTOR	173981-4
	CN205 MT 5P CONNECTOR	173981-5
	CN351 30P FFC CONNECTOR	HLEM30S-1
	JA391, J392 1P JACK	RKN1004
	JA401 2P JACK	PKB1023
	JA393 JACK	PKN1005
	X341 XTAL RES (16.9344 MHz)	PSS1008
	CN201 CONNECTOR 6P	RKP-533
	CN131 CONNECTOR	SLW16S-1C7
	X351 CERAMIC RESONATOR (4.19MHz)	VSS1014
△	TERMINAL	RKC-061

Mark No. Description Part No.

C DISPLAY BOARD ASSY

	SEMICONDUCTORS	
	D701- D704, D707	1SS254

SWITCHES

	S701, S702, S705- S708	PSG1006
	S710, S711, S713, S714	PSG1006
	S725- S727	PSG1006

OTHERS

	CN702 4P JUMPER CONNECTOR	52147-0410
	CN701 CONNECTOR	HLEM30R-1
	V701 FL INDICATOR TUBE	PEL1085

D SW BOARD ASSY

	SEMICONDUCTOR	
	D801	PCX1019

SWITCH

	S801	PSG1006
--	------	---------

A MECHANISM BOARD ASSY

	SWITCH	
	S610	DSG1016







OTHER

	CN610 MT 4P CONNECTOR	173979-4
--	-----------------------	----------

6. ADJUSTMENT

6.1 PREPARATIONS

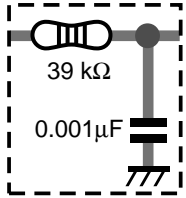
6.1.1 Jigs and Measuring Instruments

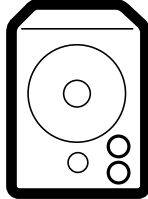
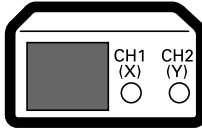
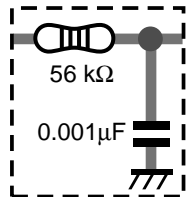
 <p>CD TEST DISC (YEDS-7)</p>	 <p>⊖ screwdriver (small)</p>	 <p>⊕ screwdriver (medium)</p>	 <p>⊕ screwdriver (large)</p>	 <p>Low pass filter ① (39 kΩ + 0.001μF)</p>
 <p>⊖ Precise screwdriver</p>	 <p>Ball point hexagon wrench (size: 1.5mm) G GK1002</p>	 <p>Low-frequency oscillator</p>	 <p>Dual-trace oscilloscope (10 : 1 probe)</p>	 <p>Low pass filter ② (56 kΩ + 0.001μF)</p>

6.1.2 Necessary Adjustment Points

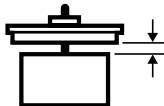
When	Adjustment points
Exchange PICKUP	1.2.3.4.5.6.7. 8.9.10.11.12 → Page 19 - 24
Exchange MAIN BOARD ASSY	1.3.5.6.7.8. 9.10.11.12 → Page 19 - 24
Exchange SERVO MECH ASSY	1.2.3.4.5.6.7. 8.9.10.11.12 → Page 19 - 24
Exchange SPINDLE MOTOR	 ADJ → Page 6

6.2 ADJUSTMENT

6.2.1 How to Start/Cancel Test Mode

TEST MODE : ON

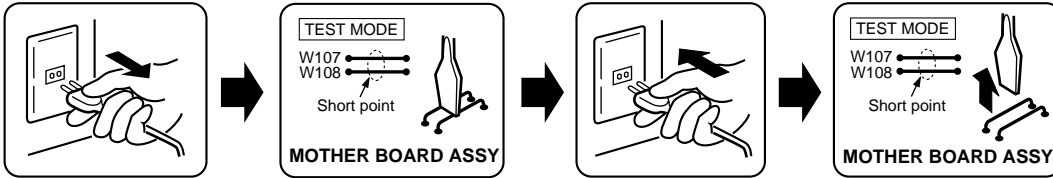

TEST MODE : PLAY

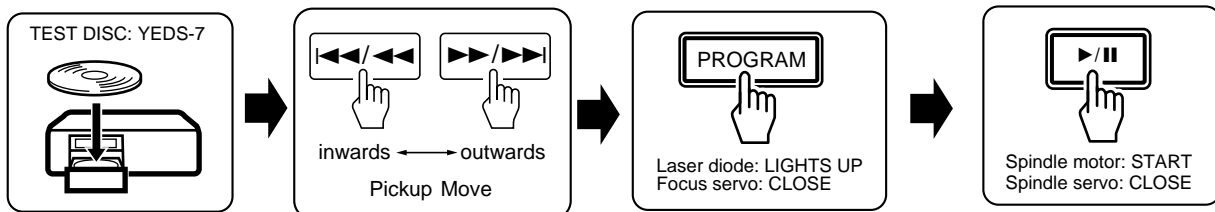

TEST MODE : STOP → CANCEL

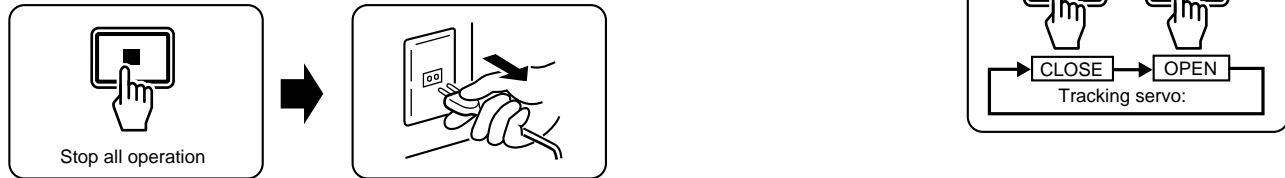

6.2.2 Adjustment Location

VR151. TR GAIN VR154. FO OFFSET
 VR152. FO GAIN VR155. TR BAL
 VR153. RF LEVEL VR156. FO BEST

(REAR)

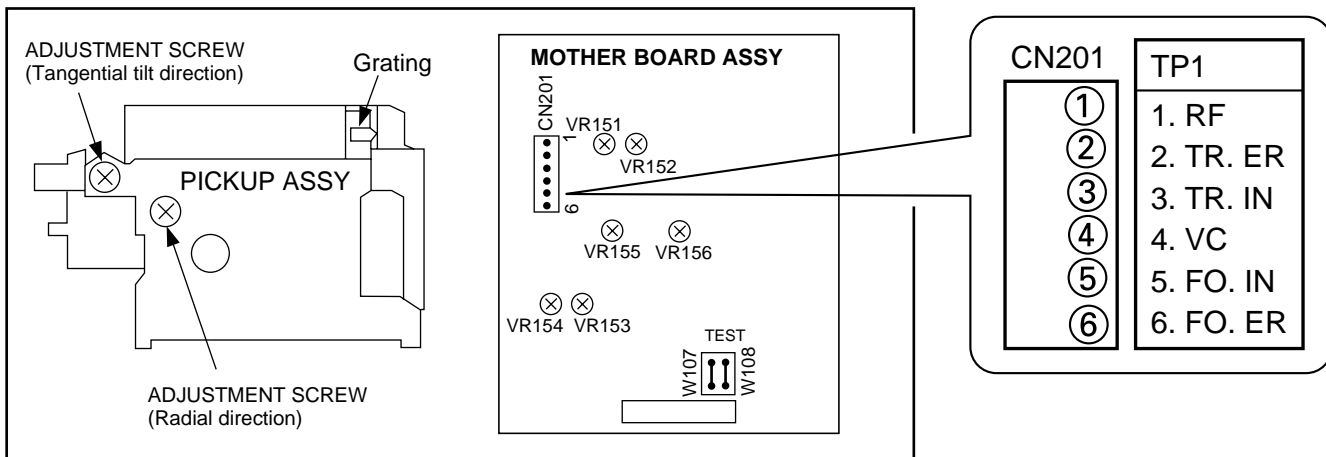

6.2.3 Check and Adjustment

1. Focus Offset Adjustment

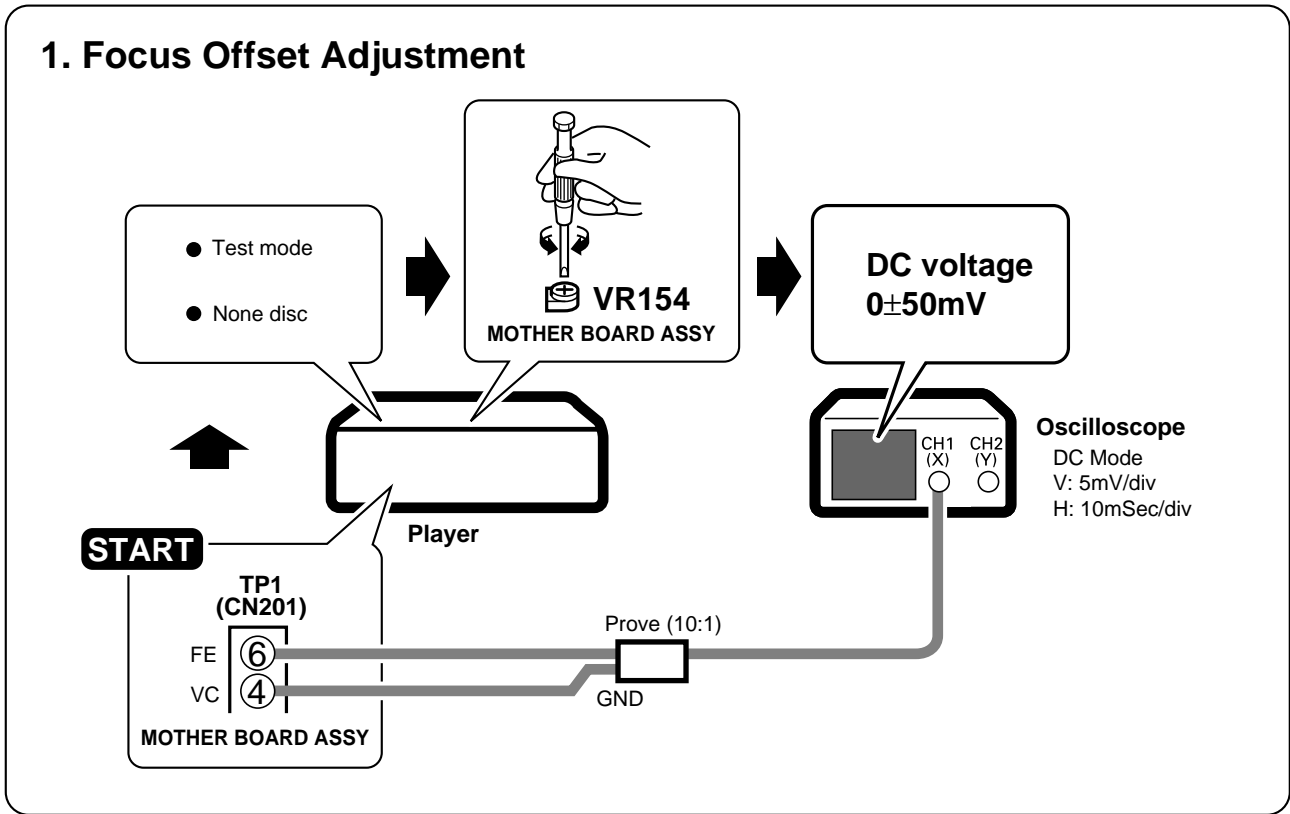

2. Grating Adjustment

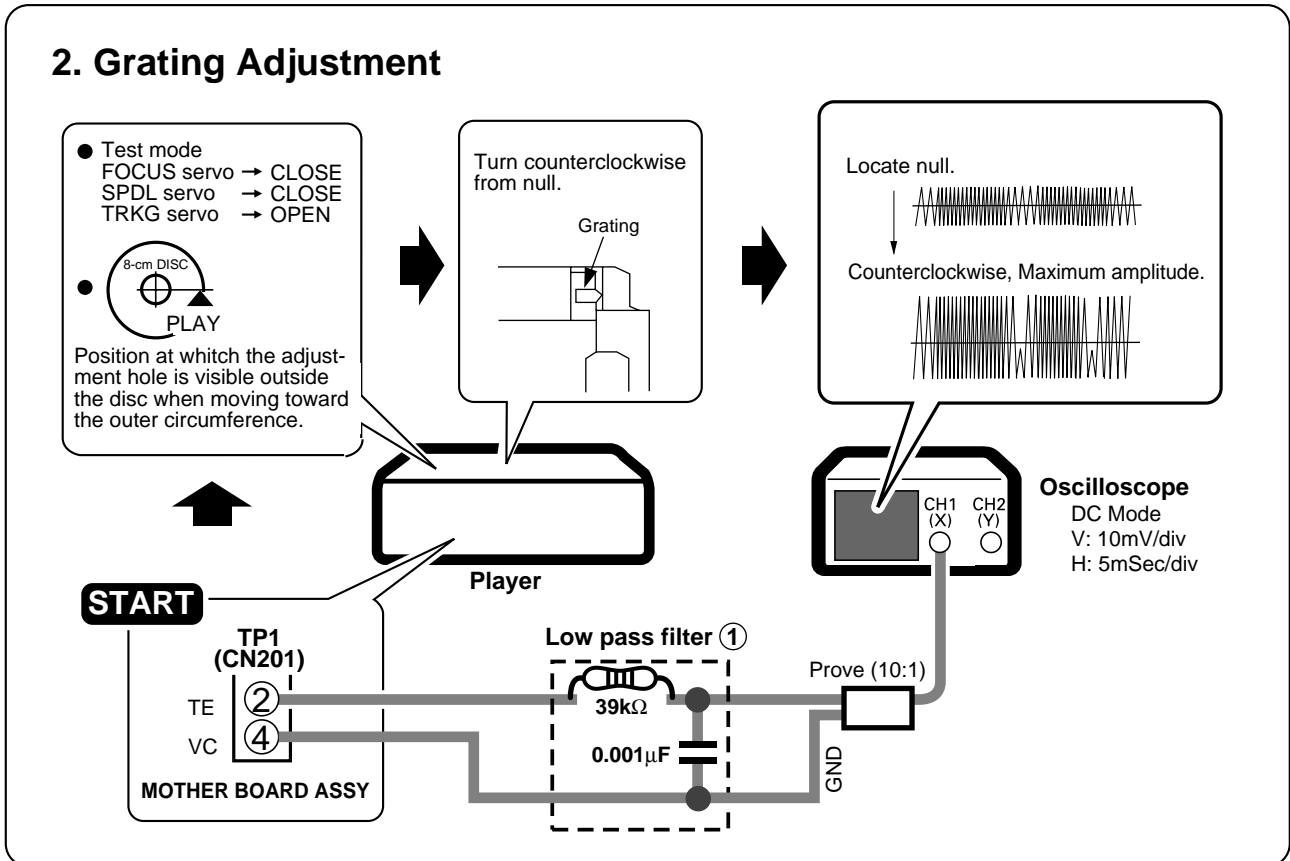

3. Tracking Error Balance Adjustment

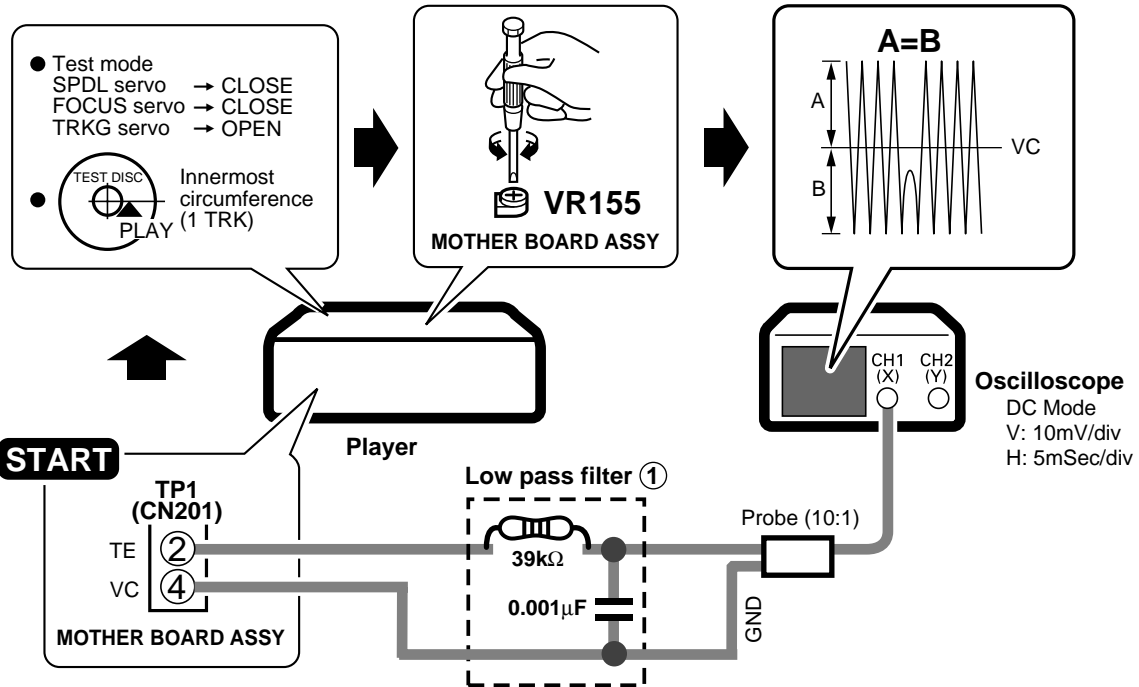

4. Pickup ①Radial ②Tangential Direction Tilt Adjustment

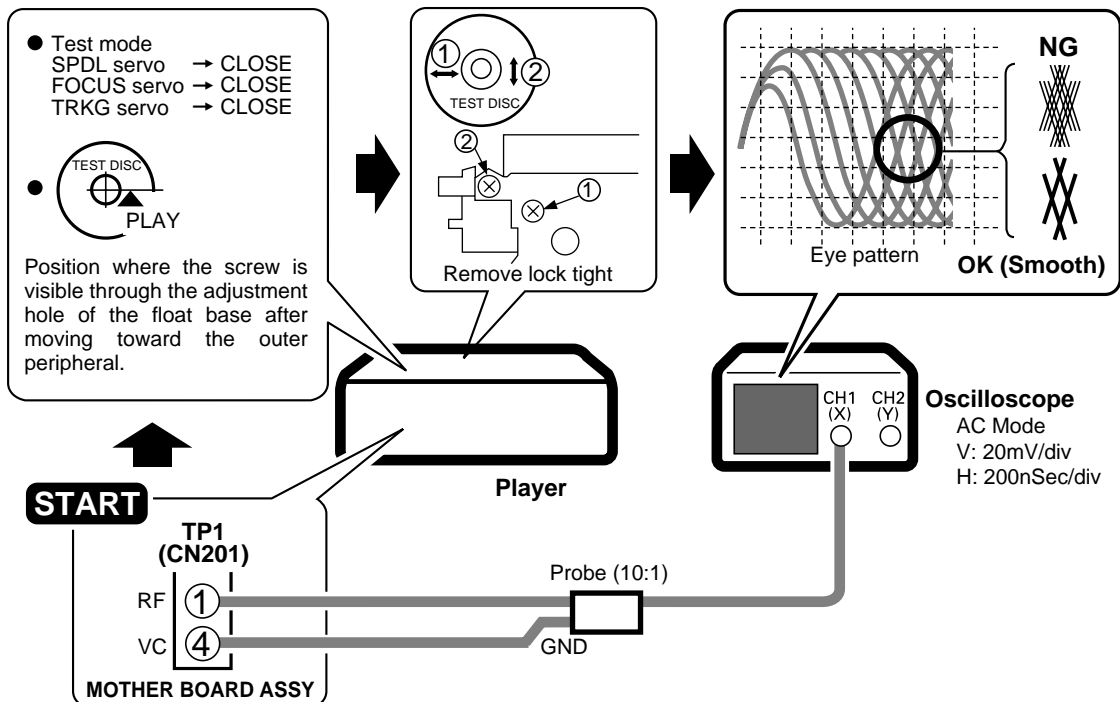

5. RF Level Adjustment I

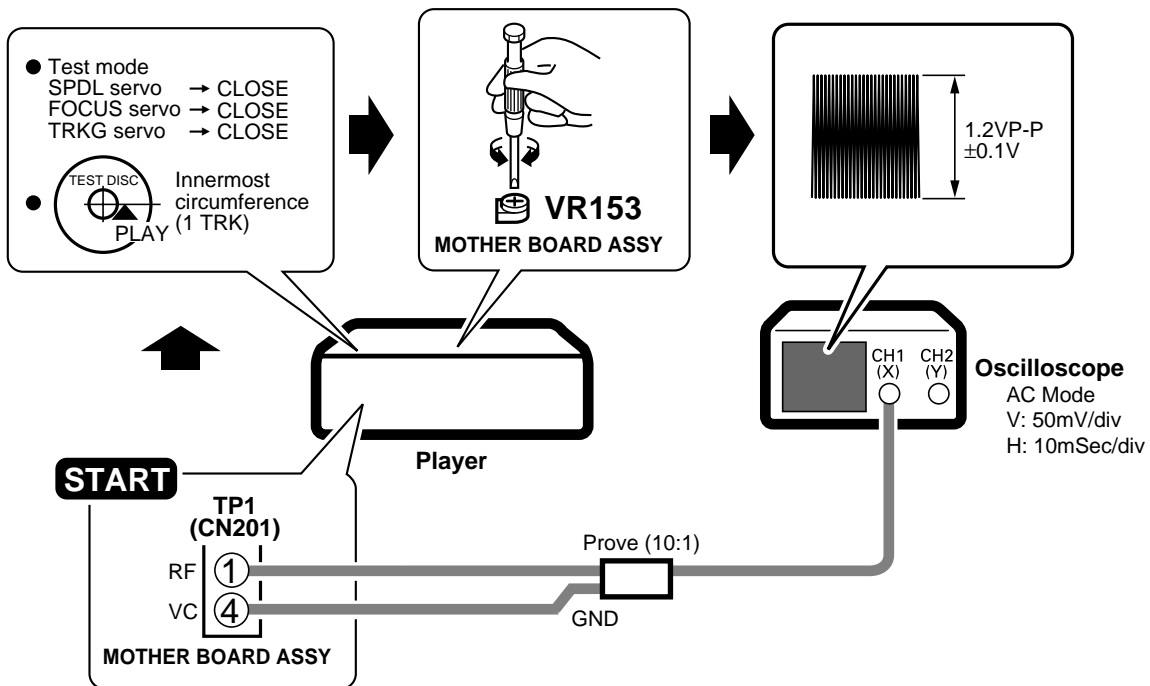

6. Focus Best Adjustment I

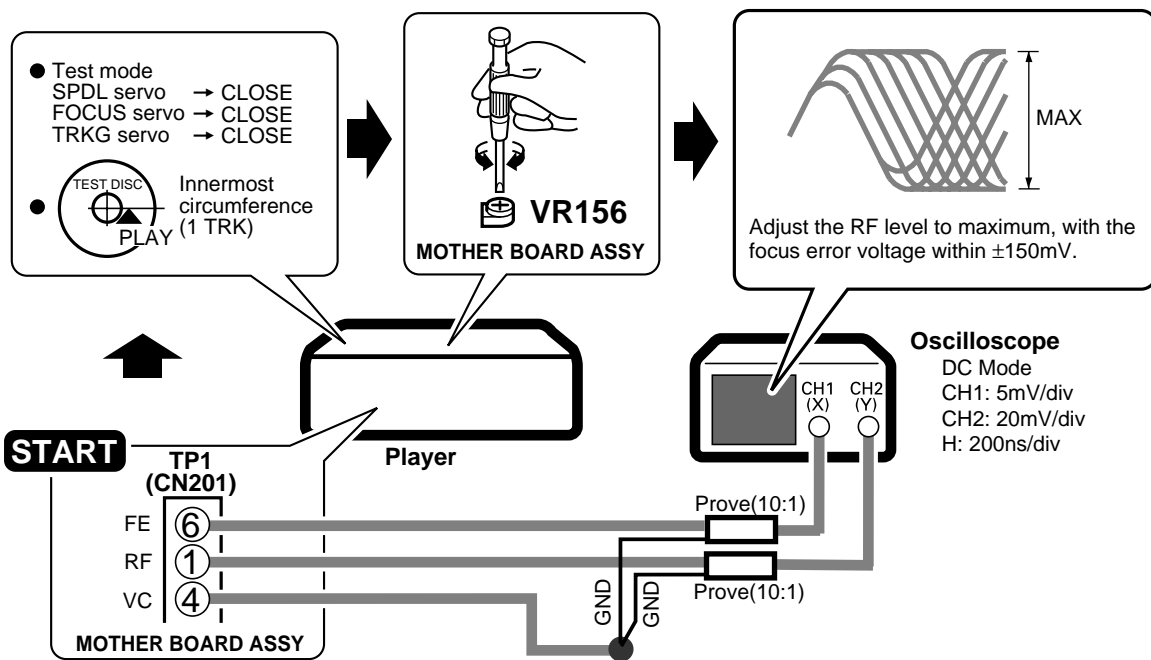

7. RF Level Adjustment II

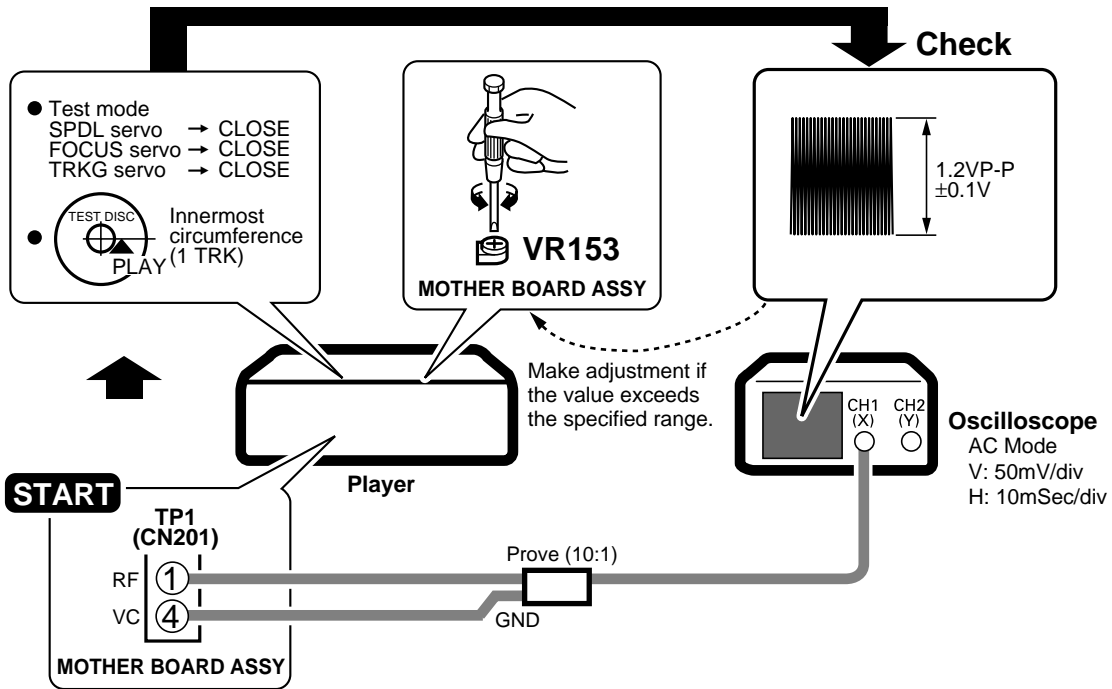

8. Focus Servo Loop Gain Adjustment I

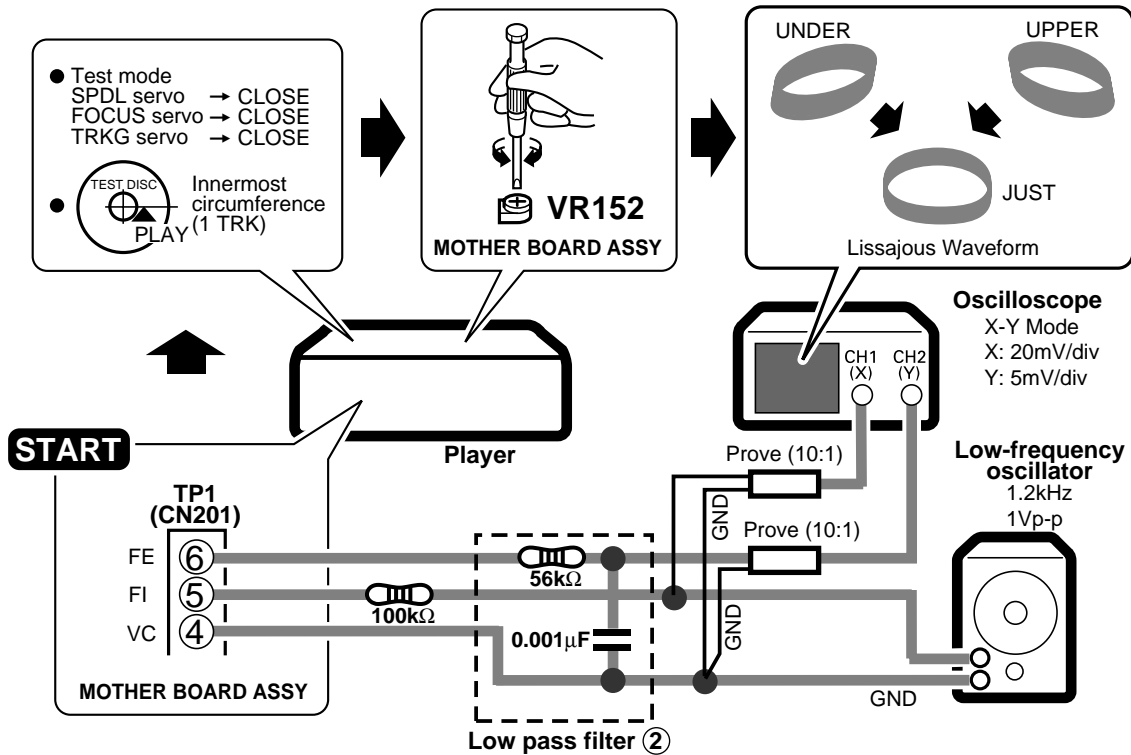

9. Focus Best Adjustment II

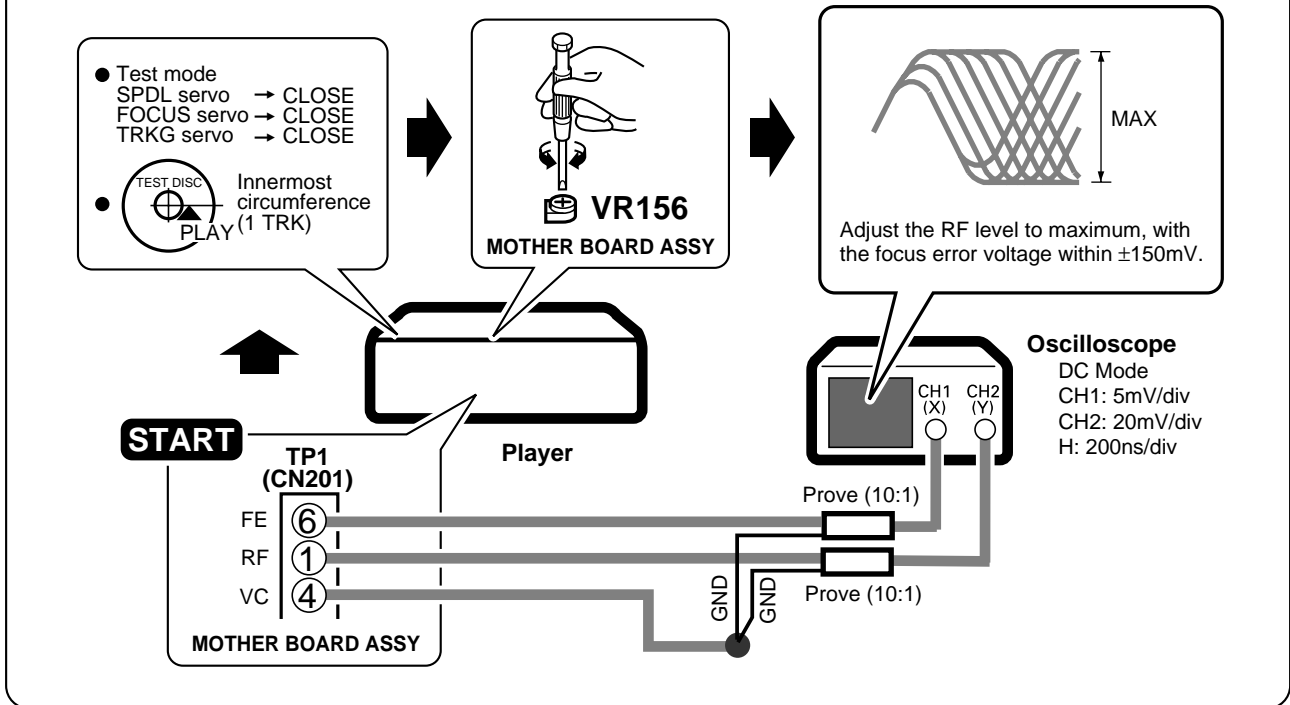

10. Focus Servo Loop Gain Adjustment II

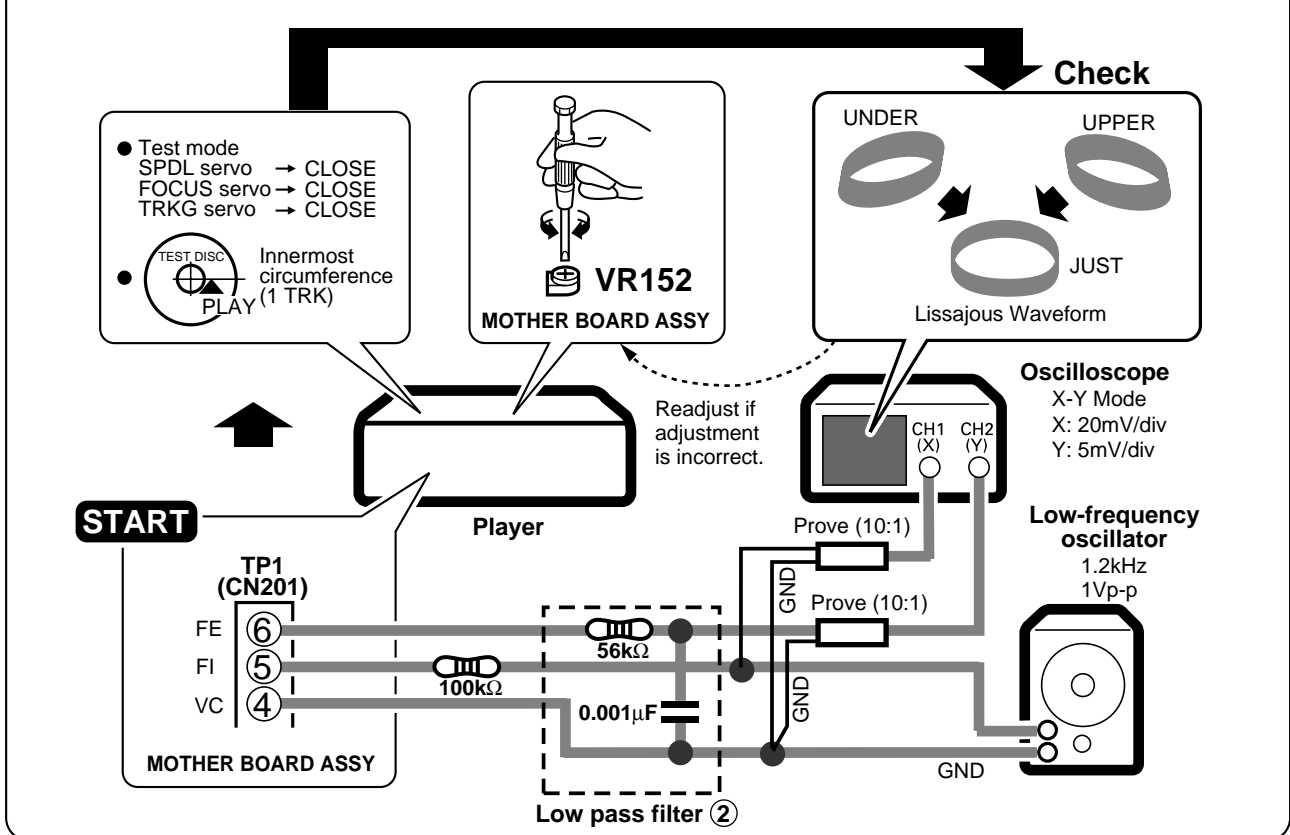

11. Focus Best Adjustment III

Adjust this point only if adjustment was made in item 10.

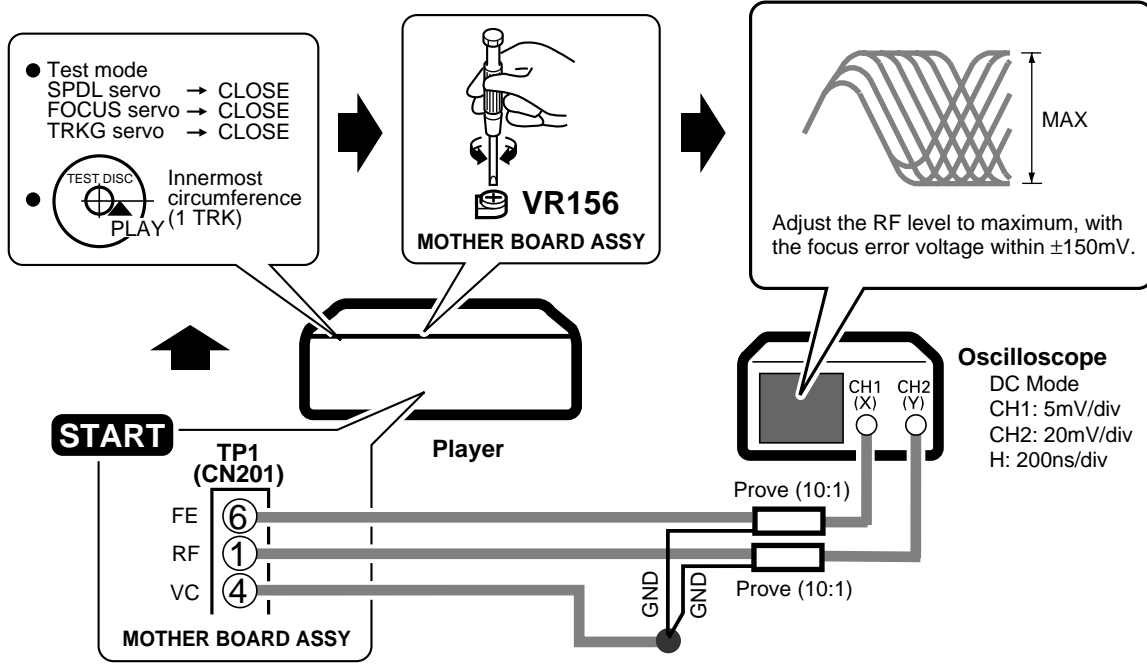

12. Tracking Servo Loop Gain Adjustment

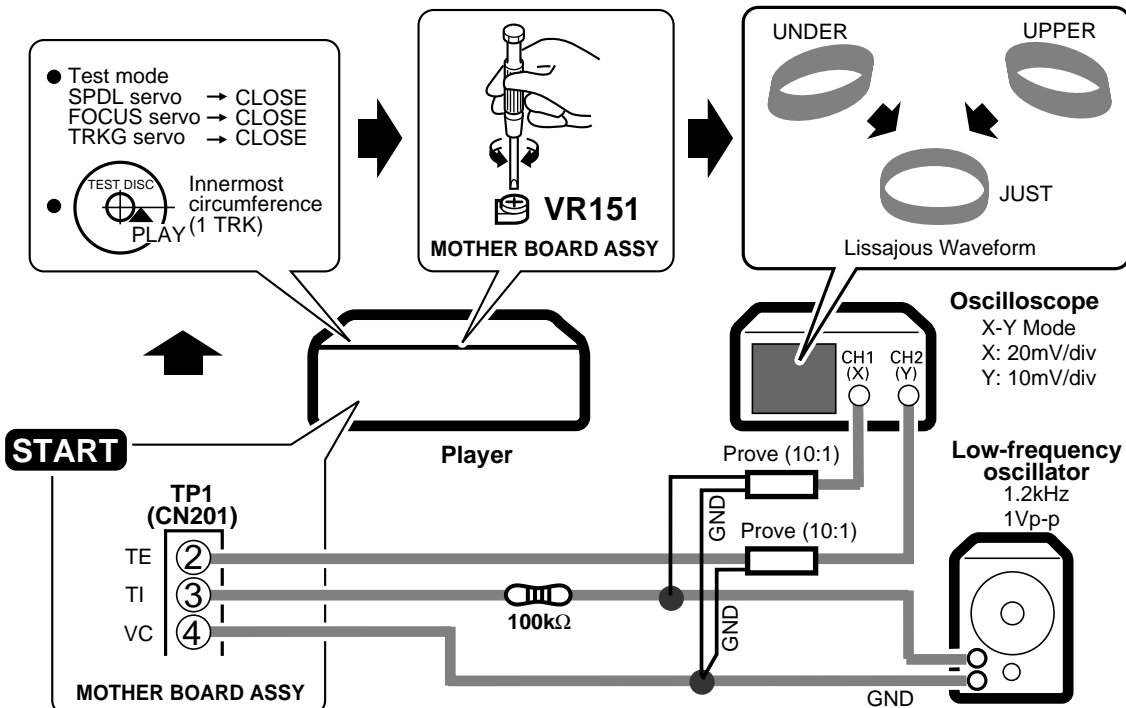

7. GENERAL INFORMATION

7.1 DISPLAY

■ PEL1085 (V701: DISPLAY BOARD ASSY)

■ FL INDICATOR TUBE

● Pin Assignment

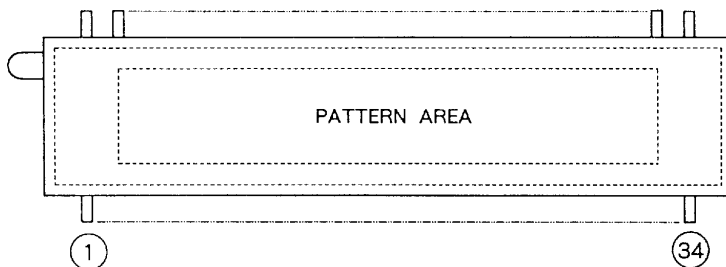

NOTE

- 1) F1, F2.....Filament
- 2) NP.....No pin
- 3) NX.....No extend pin
- 4) DL.....Datum Line
- 5) 1G - 10G.....Grid

● Pin Connection

PIN No.	1	2	3	4	5	6	7	8	9	10	11	12	13	14	15	16	17	18	19	20	21	22	23	24	25	26	27	28	29	30	31	32	33	34		
CONNECTION	F	F	N	P	P	P	P	P	P	P	P	P	P	P	1	0	9	8	7	6	5	4	3	2	1	N	N	N	N	N	N	N	N	N	F	
	1	2	P	1	2	3	4	5	6	7	8	9	0	1	2	G	G	G	G	G	G	G	G	G	G	X	X	X	X	X	X	X	X	P	X	2

● Grid Assignment

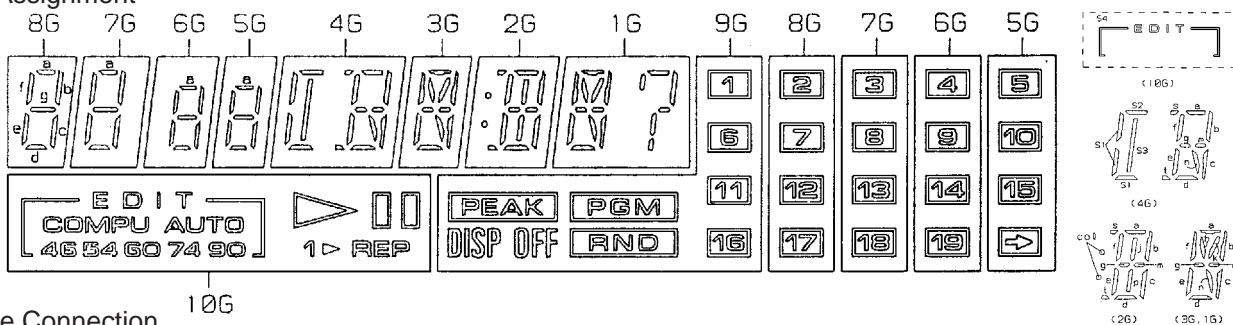

● Anode Connection

	10G	9G	8G	7G	6G	5G	4G	3G	2G	1G
P1	4G	RND	e	e	e	e	e	e	e	e
P2	5A	PGM	f	f	f	f	f	f	f	f
P3	6G	PEAK	g	g	g	g	g, m	g, m	g, m	g
P4	1▷	DISP OFF	-	-	-	-	s, t	-	s, t	m
P5	7A	-	a	a	a	a	a	a	a	a
P6	8G	-	b	b	b	b	b	b	b	b
P7	AUTO	-	c	c	c	c	c	c	c	c
P8	COMPU	-	d	d	d	d	d	d	d	d
P9	S4	1	2	3	4	5	S2	h	col	h
P10	▷	6	7	8	9	10	S3	k	j, p	k
P11		11	12	13	14	15	n	n	-	n
P12	REP	16	17	18	19	↵	S1	-	-	?

7.2 BLOCK DIAGRAM

